



Imperial College  
London

# **DTP – Gateway Review**

Rohit Roshan Nag

ME1 Design & Manufacture

# Overview

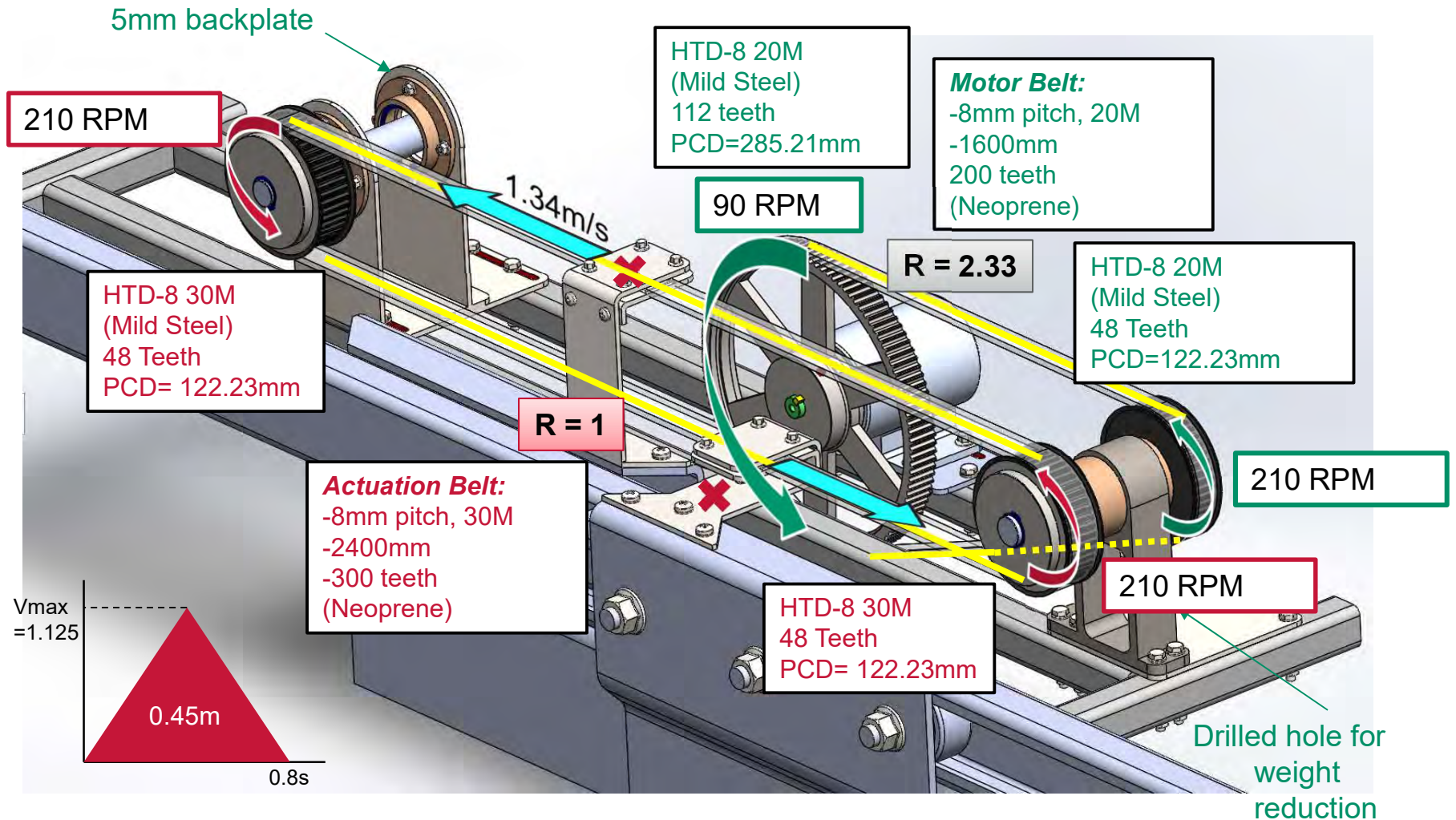

# View Profiles

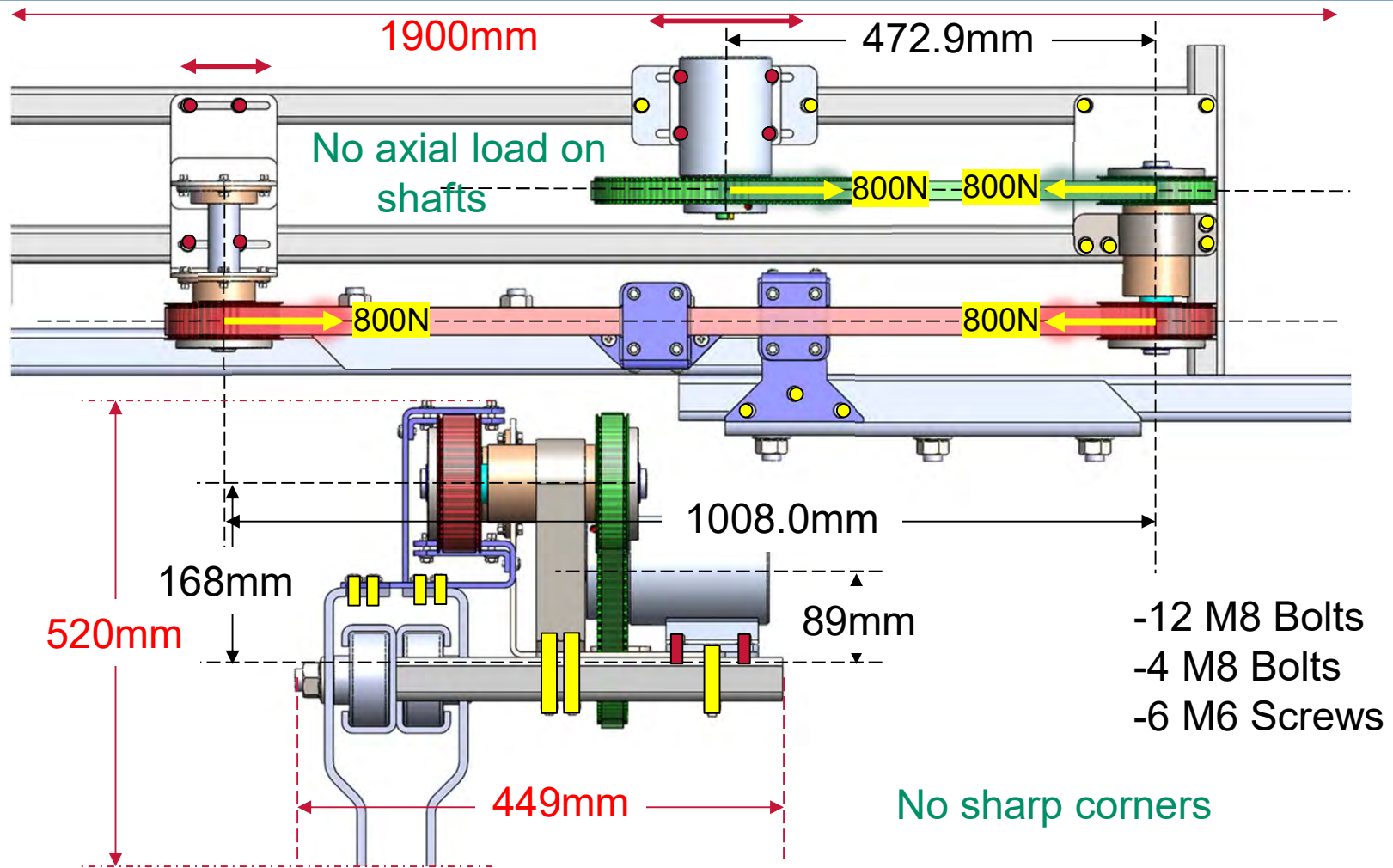



# Secondary Shaft Arrangement

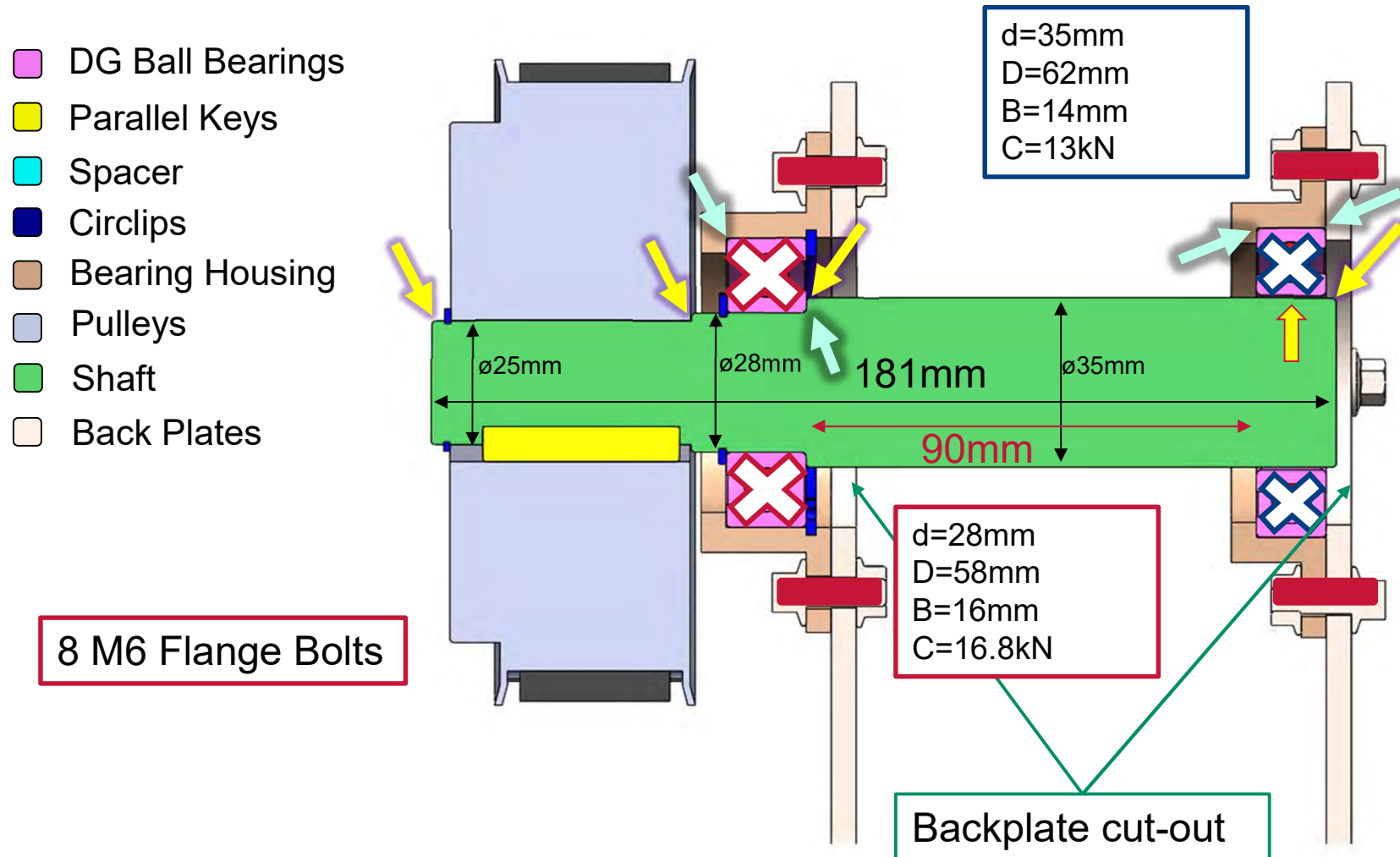

# General Attachments

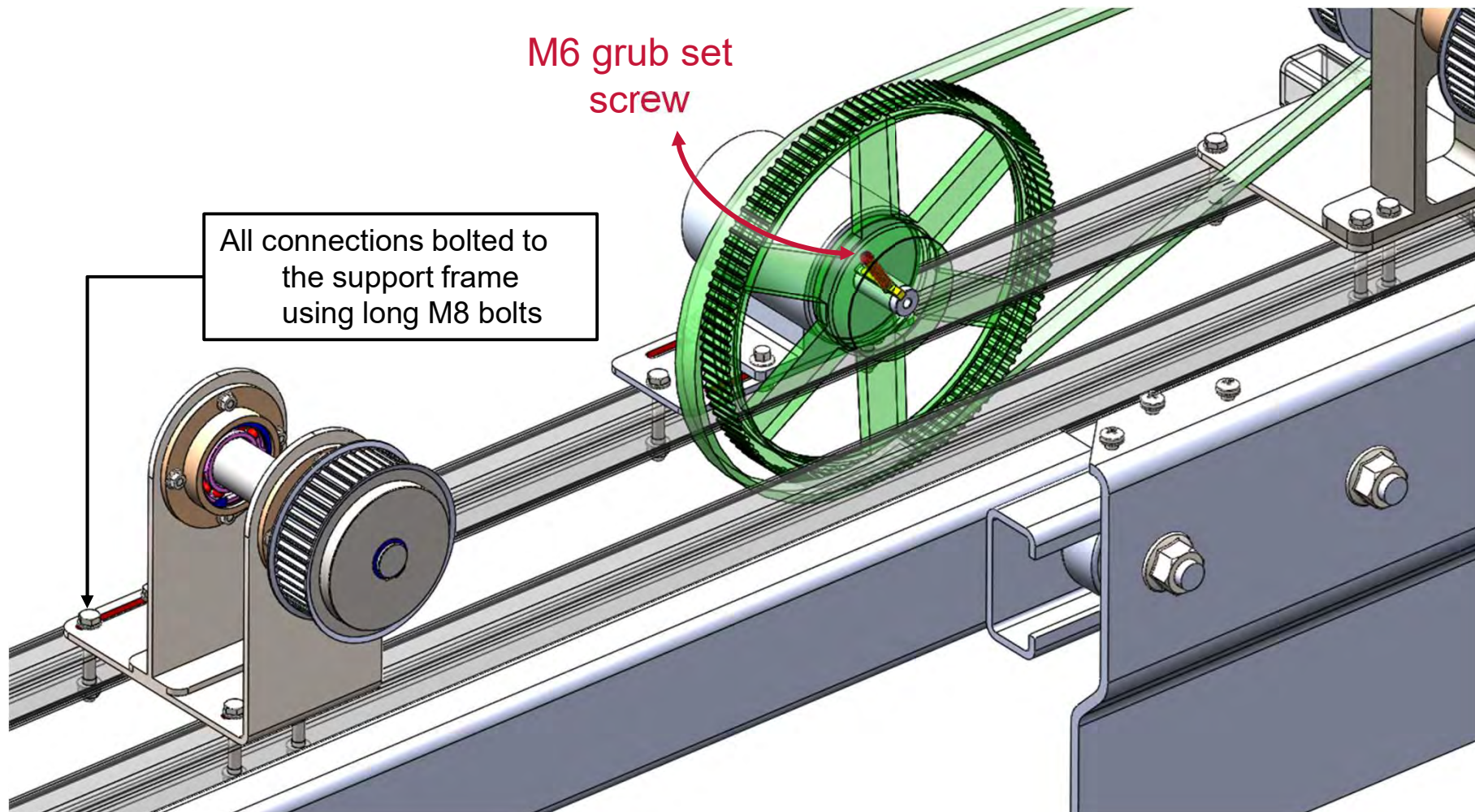

# Summary

Questions

**Thank You!**